

Diagrams

Theatre – this is a theatre style set up, with chairs facing a head table in the front of the room. It is suitable for lectures, speeches, presentations, movie watching and performances. Allows for most efficient space use.

(Example)

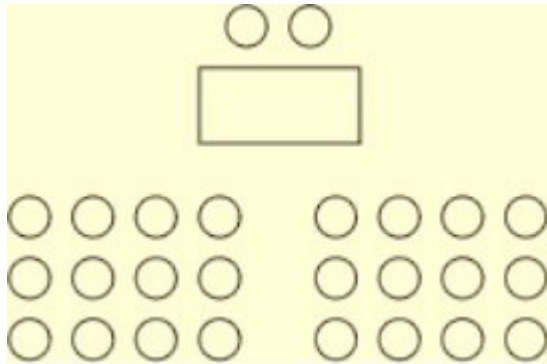

Additional chairs and tables can be provided as needed.

Classroom – usually 3 chairs on one side of the table facing a head table in the front of the room. It is suitable for workshops, orientations, and presentations where the audience will be taking notes. Relatively space consuming.

(Example)

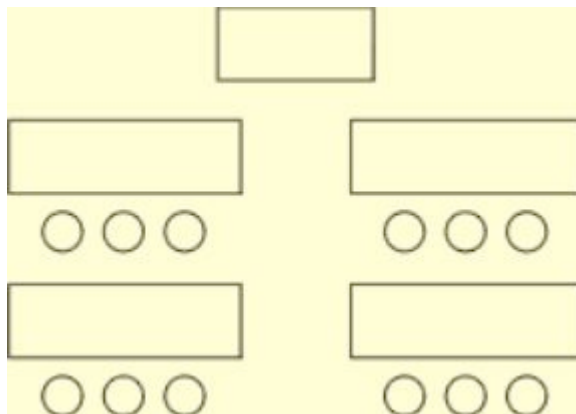

Additional chairs and tables can be provided as needed.

Herringbone – tables turned at an angle toward the head table with 3 chairs on each side of the table. It is used for presentations to allow everyone in the audience to face the speaker. More space efficient than the classroom set-up.

(Example)

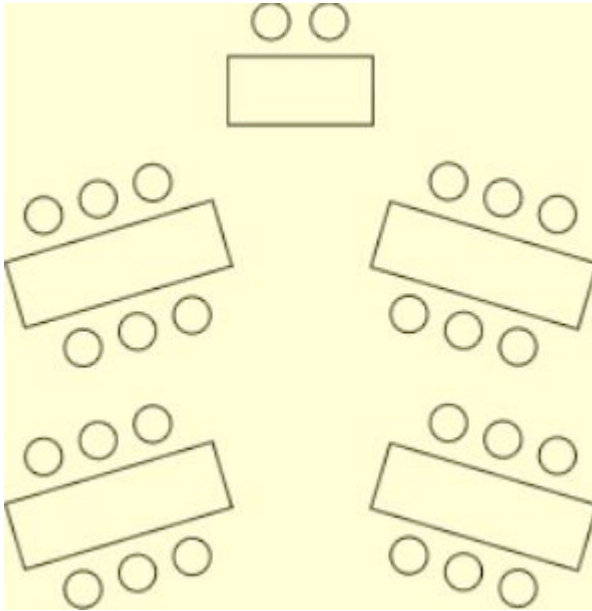

Additional chairs and tables can be provided as needed.

Square – tables moved together to form a square shape with a hollow middle and chairs around the perimeter. It is used for meetings and conferences with even number of people on each side.

(Example)

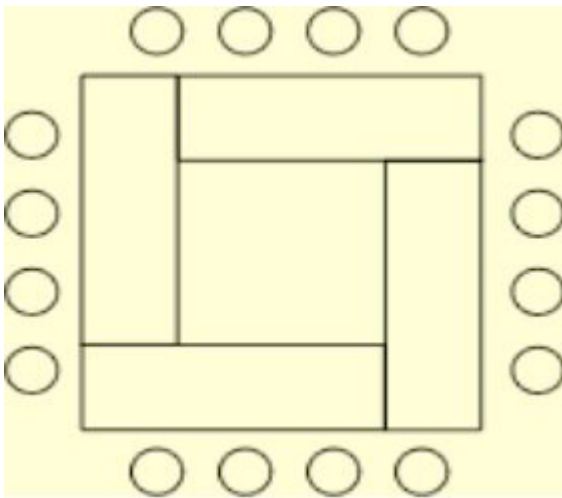

Additional chairs and tables can be provided as needed.

U-Shaped – tables are moved together to form a u-shape facing a head table with chairs around the

outside. It is used for meetings and conferences with the presenter separated from the audience. More space consuming than square and conference set-ups.

(Example)

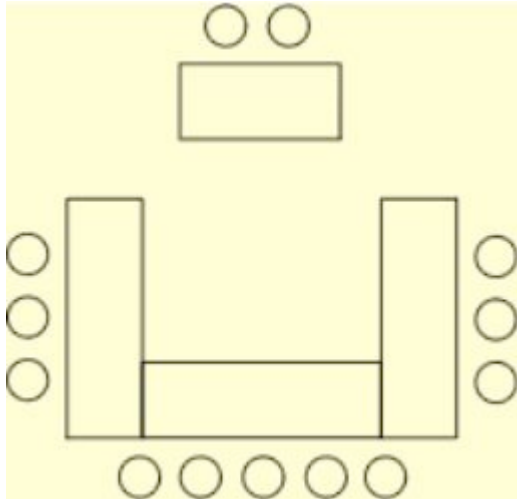

Additional chairs and tables can be provided as needed.

Banquet Dining – consists of rectangular tables pushed together to form rows, with aisles left in between the rows. This set up is used for large functions, sit down dinners, receptions, and socials. Allows for the maximum capacity use of a particular room.

(Example)

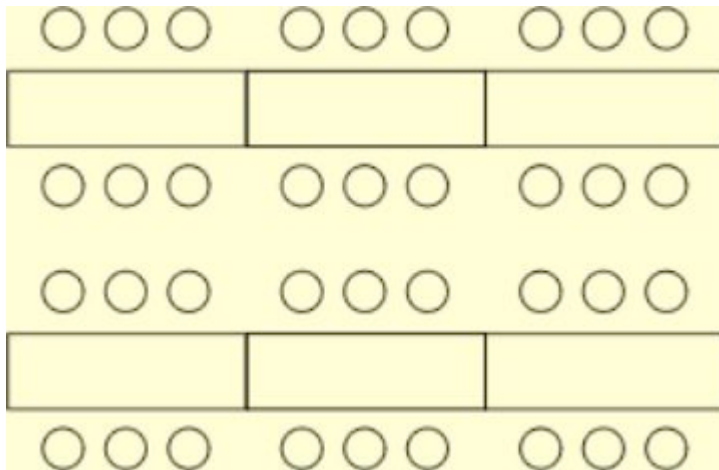

Additional chairs and tables can be provided as needed.

Rounds – most commonly used set up for dinners, receptions, celebration, and socials. Round tables allow for up to 8 people to be seated per table. This set up is much more space consuming than the

banquet style.

(Example)

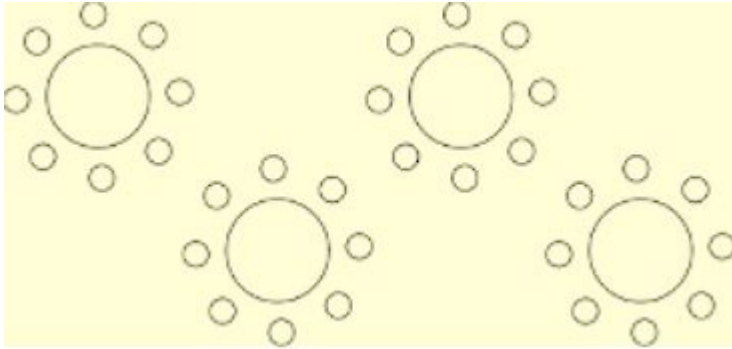

Additional chairs and tables can be provided as needed.